

M4

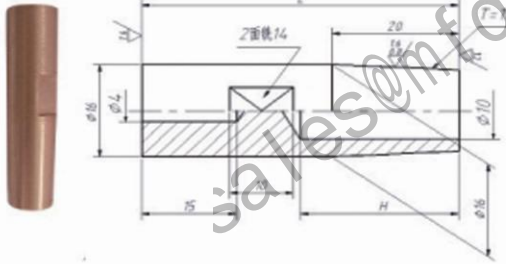

Model No.	Nut	L	H
PN-U4-50-1	M4	50	25
PN-U4-60-1	M4	60	35
PN-U4-70-1	M4	70	45

M8

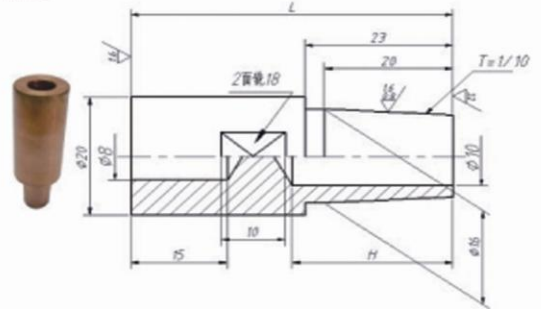

Model No.	Nut	L	H
PN-U8-50-1	M8	50	25
PN-U8-60-1	M8	60	35
PN-U8-70-1	M8	70	45

M5

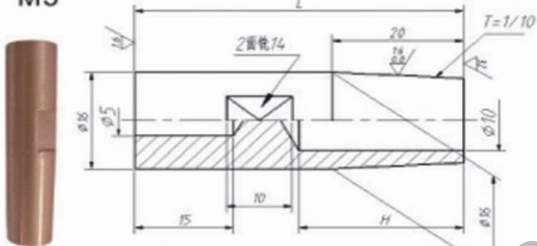

Model No.	Nut	L	H
PN-U5-50-1	M5	50	25
PN-U5-60-1	M5	60	35
PN-U5-70-1	M5	70	45

M10

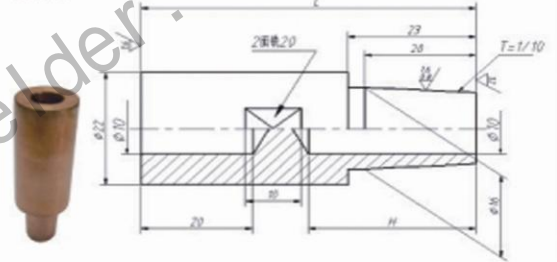

Model No.	Nut	L	H
PN-U10-60-1	M10	60	30
PN-U10-70-1	M10	70	40
PN-U10-80-1	M10	80	50

M6

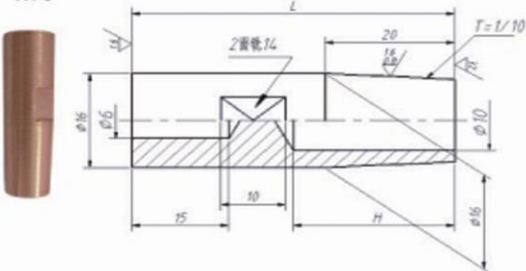

Model No.	Nut	L	H
PN-U6-50-1	M6	50	25
PN-U6-60-1	M6	60	35
PN-U6-70-1	M6	70	45

M12 7/16

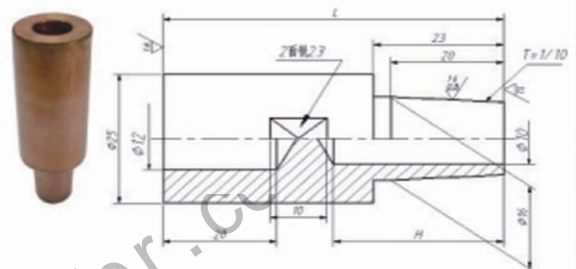

Model No.	Nut	L	H
PN-U127-60-1	M12 7/16	60	30
PN-U127-70-1	M12 7/16	70	40
PN-U127-80-1	M12 7/16	80	50

螺母上电极帽

材质：铬锆铜

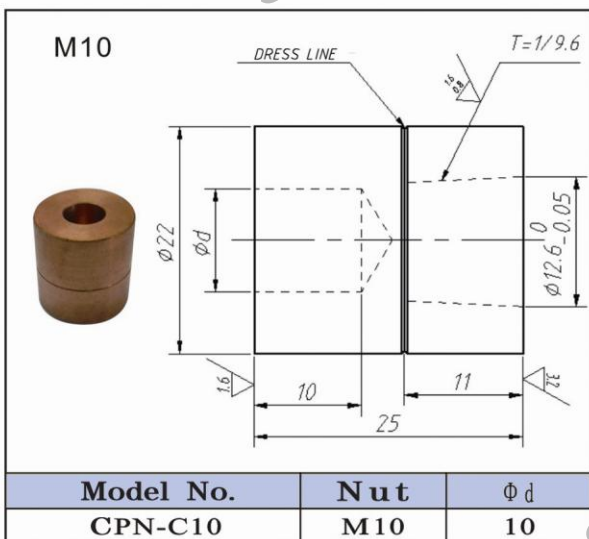
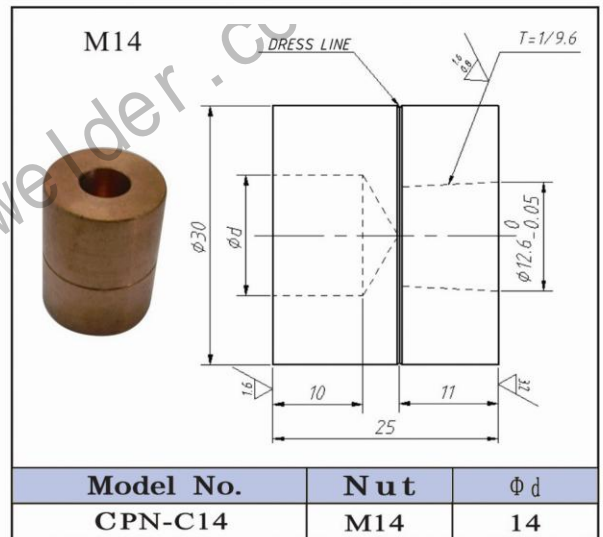
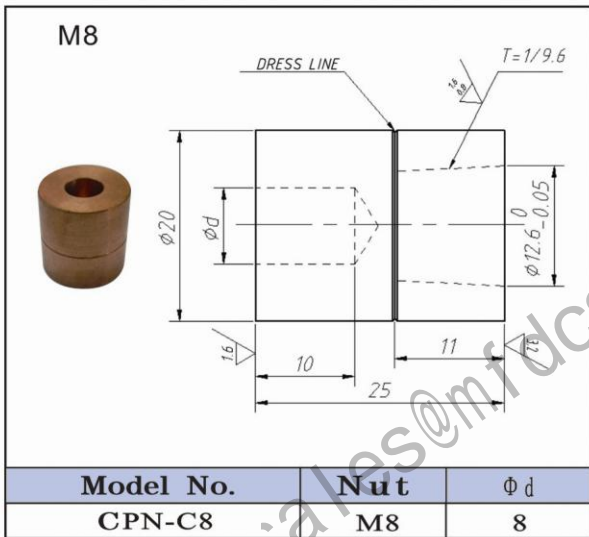
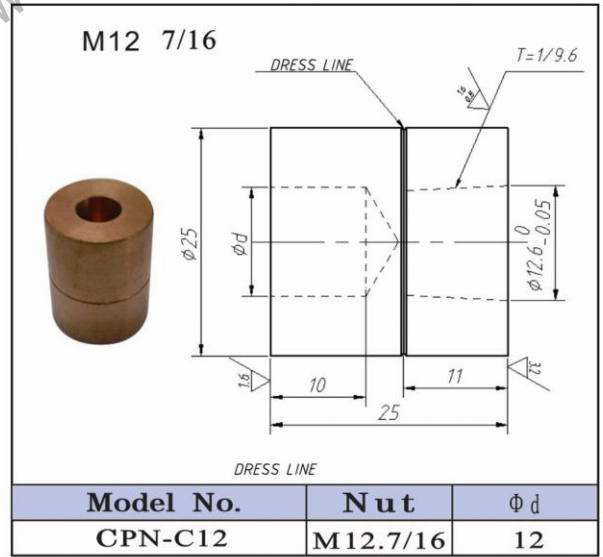
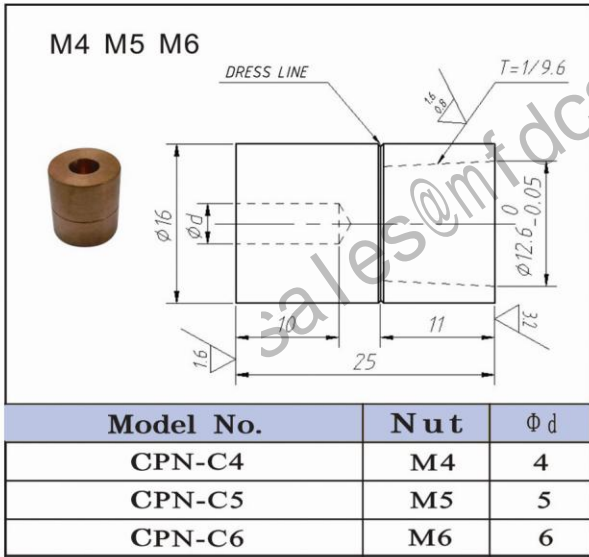

螺母下电极

材质：铬锆铜+KCF

螺母电极盖
M4 M5 M6 M8
Φ25

Model No.	Nut	Φ d
CPN-M4	M4	5
CPN-M5	M5	6
CPN-M6	M6	7
CPN-M8	M8	9

螺母电极座
Φ25

Model No.	Nut
CPN-SH1-A	1/10
CPN-SH1-B	MT#2
CPN-SH1-C	1/5

螺母电极座
Φ25

Model No.	T
CPN-H1-A	1/10
CPN-H1-B	MT#2
CPN-H1-C	1/5

螺母电极盖
Φ30

Model No.	Nut
CPN-SH2-A	1/10
CPN-SH2-B	MT#2
CPN-SH2-C	1/5

螺母电极盖
M10 M12 7/16
Φ30

Model No.	Nut	Φ d
CPN-M10	M10	11
CPN-M12	M127-7/16	13

绝缘垫 弹簧

Model No.	H	Φ D	Model No.
C-6-6-9	6	9	CSP-8-6-24
C-8-6-12	8	12	

螺母电极座
Φ30

Model No.	T
CPN-H2-A	1/10
CPN-H2-B	MT#2
CPN-H2-C	1/5

可调气管接头
PT1/8-φ6

参考组立图