

螺栓上电极帽 (头) (Tips for Bolt Welding)

Material: CuCrZr

螺栓上电极帽

螺栓上电极头

M4 M5 M6

Model No.	Bolt
PB-U-C456	M4·M5·M6

M4 M5 M6

Model No.	Bolt	L
PB-U456-60-1	M4·M5·M6	60
PB-U456-70-1	M4·M5·M6	70
PB-U456-80-1	M4·M5·M6	80

M8 M10

Model No.	Bolt
PB-U-C810	M8·M10

M8 M10

Model No.	Bolt	L
PB-U810-60-1	M8·M10	60
PB-U810-70-1	M8·M10	70
PB-U810-80-1	M8·M10	80

M12 7/16

Model No.	Bolt
PB-U-C127	M12·7/16

M12 7/16

Model No.	Bolt	L
PB-U127-60-1	M12·7/16	60
PB-U127-70-1	M12·7/16	70
PB-U127-80-1	M12·7/16	80

螺栓下电极

材质：铬锆铜+KCF

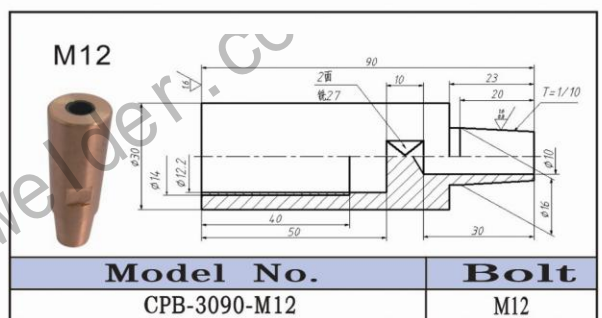
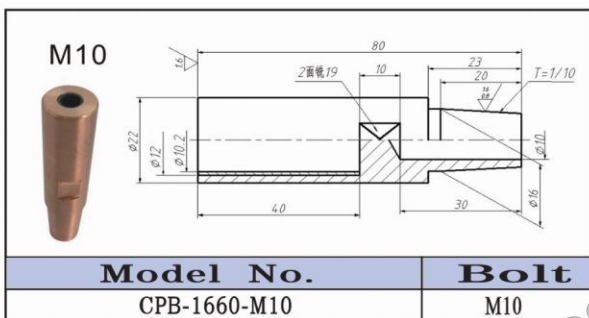
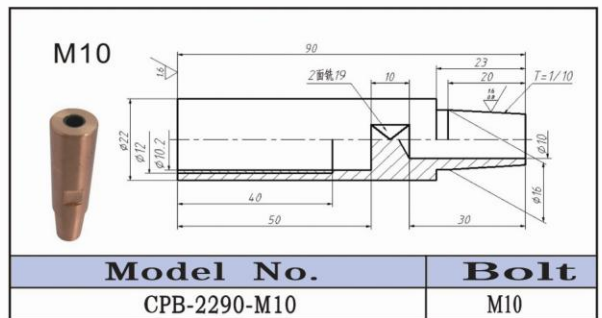
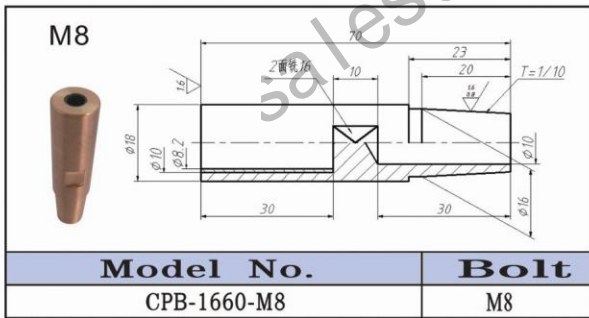
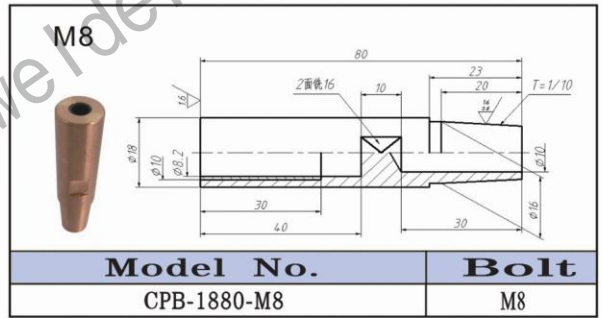
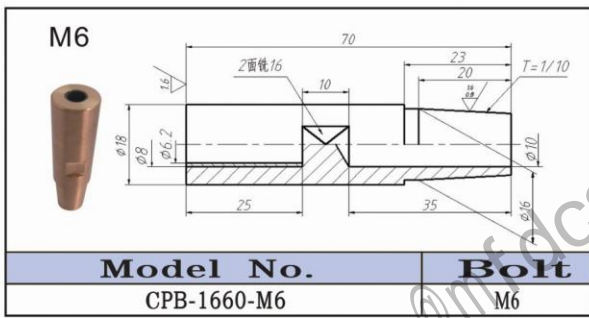
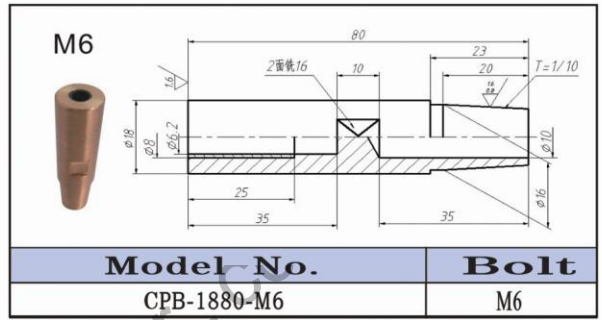
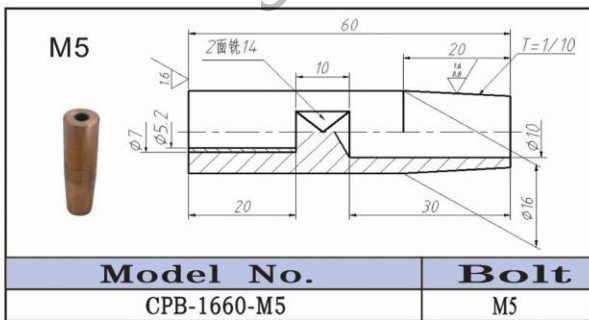
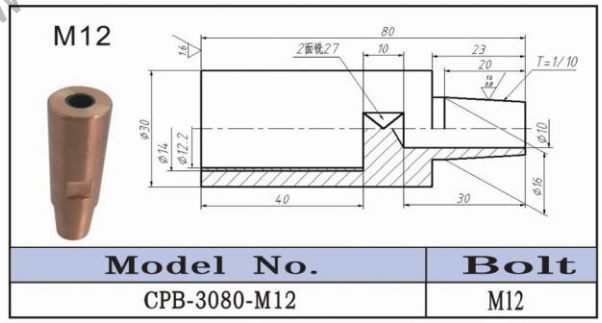
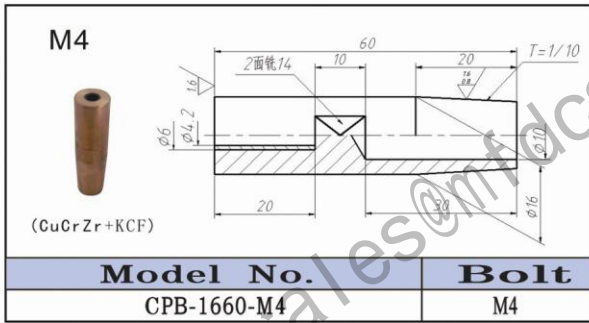

螺栓下电极

材质: 铬锆铜+KCF

螺栓电极座

Φ25

Model No.	T
CPB-H1-65-A	1/10
CPB-H1-65-B	CT#2

螺栓电极盖 M8

Φ25

Model No.	Bolt
CPB-2532-M8	M8

螺栓电极盖 M4

Φ25

Model No.	Bolt
CPB-2527-M4	M4

螺栓电极座

Φ30

Model No.	T
CPB-H2-65-A	1/10
CPB-H2-65-B	MT#2

螺栓电极盖 M5

Φ25

Model No.	Bolt
CPB-2527-M5	M5

螺栓电极盖 M10

Φ30

Model No.	Bolt
CPB-3042-M10	M10

螺栓电极盖 M6

Φ25

Model No.	Bolt
CPB-2527-M6	M6

螺栓电极盖 M12

Φ30

Model No.	Bolt
CPB-3042-M12	M12